

1242 Laser Transmitter

User Guide



Introduction

Thank you for choosing the 1242 Spectra Precision Laser from the Trimble family of precision lasers. You've just made a wise investment in field-proven products made by the world's largest manufacturer of laser-based leveling, alignment, and grade-control systems.

The 1242 is a simple-to-use tool that allows you to take accurate horizontal measurements up to 60 m (200 ft) away visually or 400 m (1300 ft) away using a hand-held receiver. Each system component is designed for ALL construction leveling and surveying tasks requiring tight tolerances...under all environmental conditions.

This manual introduces you to the 1242 laser system. Use the manual now to learn basic skills, and use it later as a reference book. You don't need to know anything about the 1242 laser to use this manual. Everything you need to know is explained as you go along. The great thing about this laser system is that once you learn a few techniques, you'll use those same techniques whenever you use this system—no matter what your leveling requirements are.

You'll get years of service from your reliable, state-of-the-art system by following the recommendations in this manual. Your comments and suggestions are welcome; please call the Trimble Engineering and Construction Division for your local, authorized Trimble office.

Trimble Engineering and Construction Division

5475 Kellenburger Road

Dayton, Ohio 45424-1099 U.S.A.

Phone: (937) 233-8921

(800) 538-7800

Fax: (937) 233-9004

Internet: www.trimble.com

Claim for Damage in Shipment

The 1242 laser system includes a laser, receiver, quick clamp, operator's manual, laser safety kit, carrying case, and batteries. Optional accessories include a scope and battery recharging kit.

You should inspect your laser system as soon as you receive it. It has been packaged for safe delivery. If it is damaged in any way, immediately file a claim with the carrier or, if insured separately, with the insurance company.

Safety Information

Included in this manual are **CAUTIONS** and **Notes**. Each of these words represents a level of danger or concern.

A **CAUTION** indicates a hazard or unsafe practice that could result in *minor* injury or property damage.

A **Note** indicates important information unrelated to safety.

Table of Contents

	Page
Introduction	i
Claim for Damage in Shipment	ii
Safety Information	ii
Table of Contents.	iii
Features & Functions	1
Laser	1
How to Use the 1242 Laser System	4
Laser	4
Installing the Batteries	4
Attaching the Laser to a Tripod	5
Setting Up the Laser in Automatic Self-Leveling Mode	6
Setting Up the Laser in Grade Mode	8
Setting Up the Laser in Manual Mode	10
General Construction Uses	12
Determining the Height of Instrument (HI).	12
Establishing 4-Foot (1-Meter) Reference Marks	13
Determining the Difference in Elevation	16
Using the Point-Control Knob for Grade-Axis-Alignment	
Applications	18
General Application.	18
Short-Run Pipe Laying Application.	19
Specifications	20
Maintenance and Care	21
Storage	21
Battery Disposal.	21
System Cleaning	21
Troubleshooting	22
Calibration.	23
Service	27
Laser Safety	30
EMC Declaration of Conformity	32
Warranty	33

Features and Functions

Laser

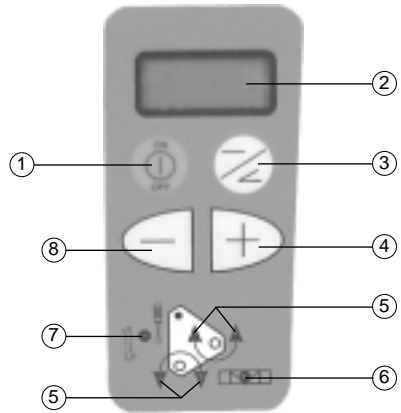

1. **Power Button** – turns the laser on/off.
2. **Liquid Crystal Display (LCD)** – shows the laser's operating modes, percentage of grade, approximate charge of the batteries, and beam's rotation speed.
3. **Mode Button** – allows you to choose the laser's operating modes, which include automatic self-leveling, grade, and manual.
4. **Increase Button** – is a multifunctional button that allows you to increase the laser's percentage of grade in grade mode and the beam's rotation speed in self-leveling and manual mode.
5. **Leveling Screws LEDs** – flash while the laser self levels in automatic self-leveling or grade mode.
6. **Level LED** – lights (green) when the laser has self leveled in automatic self-leveling or grade mode.
7. **SafeGuard™ LED** – flashes if the laser has received an impact that could have caused the self-leveled laser beam to be out of calibration.
8. **Decrease Button** – is a multifunctional button that allows you to decrease the laser's percentage of grade in grade mode and the beam's rotation speed in self-leveling and manual mode.

Laser (cont.)

9. **Pointing-Control Knob** – allows you to point the laser beam when it is not rotating.
10. **Sunshade** – protects the lighthouse.
11. **Lighthouse** – is the 360° exit window for the laser beam. The lighthouse is sealed and protects the internal components from the environment.
12. **Handle** – allows you to carry the laser easily.
13. **Leveling Screws** – allow you to adjust the laser beam so that it matches an existing grade when the laser is in manual mode.
14. **Leveling Base** – supports the laser while it's on the tripod. The leveling base also allows you to use the laser freestanding.
15. **Battery Recharging Jack** – is the port that the battery recharger plugs into.



16. **Battery Housing** – holds four D-cell alkaline or Ni-Cd batteries.



17. **Calibration Screws** – allow you to adjust the calibration of the laser beam.

18. **5/8-11 Tripod Mount** – allows the laser to be attached to a standard 5/8-11 tripod or column mount.

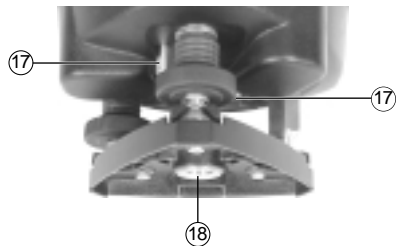

How to Use the 1242 Laser System

Laser

Installing the Batteries

CAUTION: Do not attempt to recharge alkaline batteries. Doing so could cause damage to the battery housing.

Note: The laser has reverse polarity protection. If the batteries are put in wrong, no damage occurs to the laser but it does not work. Allow it one minute to recover after the batteries have been installed correctly.

1. Turn the battery-housing knob counterclockwise to release the battery-housing door.



2. Insert the batteries as shown noting the positive (+) and negative (-) diagram inside the housing.



3. Put the battery-housing door in place and turn the battery-housing knob clockwise.



Attaching the Laser to a Tripod

1. Insert the $\frac{5}{8}$ -11 tripod screw into the laser's $\frac{5}{8}$ -11 threaded insert.

Note: The laser can also be attached to a column clamp or other mounting device.

2. Turn the screw counterclockwise to hold the laser securely in place.



Setting Up the Laser in Automatic Self-Leveling Mode

The laser can be used with or without a tripod. If you are using the laser without a tripod, make sure you set the laser on a stable surface.

1. Set up a tripod to the height appropriate for your application needs.



2. Attach the laser to the tripod. See “Attaching the Laser to a Tripod” for more information.

3. Press the power button.

Note: The laser always starts up in automatic self-leveling mode. When the laser is initially turned on, the LCD shows the approximate charge of the batteries (for about 10 seconds) and the leveling-screws LEDs flash to show the direction that the leveling screws are turning to level the laser. When the laser is level, three dashes appear in the LCD (---), the level LED lights, and the laser beam rotates at 600 rpm (the speed needed for use with a receiver).



Setting Up the Laser in Automatic Self-Leveling Mode (cont.)

4. Select the beam rotation speed that is appropriate for your application needs.

To decrease the rotation speed, press the decrease button. To increase the rotation speed, press the increase button.



Four rotation speeds are available:

- SP0 0 rpm, can be used for sewer pipe and alignment applications
- SP1 50 rpm, can be used for interior alignment applications
- SP2 300 rpm, can be used for interior and machine control applications
- SPF 600 rpm, the speed needed for use with a receiver

Setting Up the Laser in Grade Mode

1. Set up a tripod to the height appropriate for your application needs.

2. Attach the laser to the tripod. See “Attaching the Laser to a Tripod” for more information. Make sure that the handle is directly over a tripod leg so that you can incline the tripod in the up-grade direction. Grade is set in the direction of the up-grade label.



3. Press the power button.

Note: When the laser is initially turned on, it is in automatic self-leveling mode and the LCD shows the approximate charge of the batteries.



4. Press the mode button once to change the laser from automatic self-leveling mode to grade mode.

Note: The percentage of grade last entered into the laser appears in the LCD. The grade can be quickly adjusted to 0.10% (minimum amount of grade in grade mode) by simultaneously pressing and holding the increase and decrease buttons.



Setting Up the Laser in Grade Mode (cont.)

5. Select the percentage of grade that is appropriate for your application needs. To decrease the percentage of grade, press and hold the decrease button. To increase the percentage of grade, press and hold the increase button. When the desired grade appears in the LCD, the laser automatically adjusts to the grade shown.



Note: If the leveling screws LEDs continue to flash after the laser has tried to self level, the laser is beyond its self-leveling range. To get the laser within its self-leveling range, turn the leveling screws in the direction shown by the leveling screws LEDs or incline the tripod in the up-grade position.



Note: For grades between 10% and 25% (maximum amount in grade mode), incline the tripod in the up-grade direction.

Note: When the laser is in grade mode, the beam's rotation speed is 600 rpm.



Setting Up the Laser in Manual Mode

1. Set up a tripod to the height appropriate for your application needs.
2. Attach the laser to the tripod. See “Attaching the Laser to a Tripod” for more information.



3. Press the power button.

Note: When the laser is initially turned on, it is in automatic self-leveling mode and the LCD shows the approximate charge of the batteries.



4. Press the mode button twice to change the laser from automatic self-leveling mode to manual mode.



Setting Up the Laser in Manual Mode (cont.)

5. Make sure the beam's rotation speed is appropriate for your application needs.

To decrease the rotation speed, press the decrease button. To increase the rotation speed, press the increase button.



Four rotation speeds are available:

- SP0 0 rpm, can be used for sewer pipe and alignment applications
- SP1 50 rpm, can be used for interior alignment applications
- SP2 300 rpm, can be used for interior and machine control applications
- SPF 600 rpm, the speed needed for use with a receiver

6. Adjust the leveling screw(s) until the laser beam matches the desired slope or grade.



General Construction Uses

Determining the Height of Instrument (HI)

The height of instrument (HI) is the elevation of the laser's beam. The HI is determined by adding the grade-rod reading to a benchmark or known elevation.

1. Set up and level the laser as described in "Setting Up the Laser in Automatic Self-Leveling Mode."
2. Attach the receiver to a grade rod and turn on the receiver. For more information about using your receiver, see the receiver's operator's manual.
3. Place the grade rod on a job-site benchmark (BM) or known elevation.
4. Slide the receiver up/down the grade rod until the LCD shows an on-grade reading. For more information about using your receiver, see the receiver's operator's manual.
5. Add the grade-rod reading to the benchmark to determine the height of instrument.

Example: Benchmark elevation = 30.55 m (100.23 ft)

On-grade rod reading = 1.32 m (4.34 ft)

Height of instrument = 31.87 m (104.57 ft)

Height of Instrument (HI)

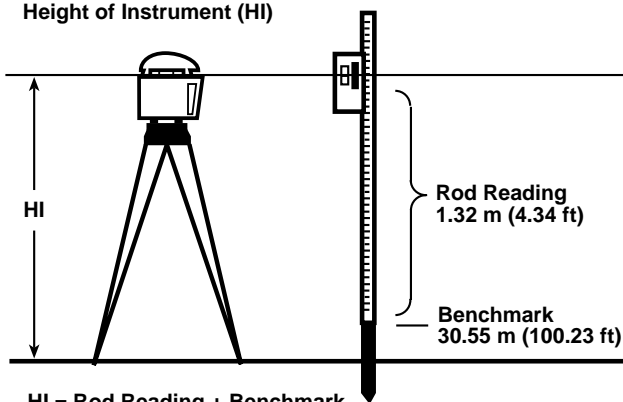

$$HI = \text{Rod Reading} + \text{Benchmark}$$

$$HI = 1.32 \text{ m} + 30.55 \text{ m} = 31.87 \text{ m} \quad (4.34 \text{ ft} + 100.23 \text{ ft} = 104.57 \text{ ft})$$

6. Use this HI as a reference for all other elevations.

Establishing 1-Meter (4-Foot) Reference Marks

1. Set up and level the laser as described in “Setting Up the Laser in Automatic Self-Leveling Mode.”
2. Determine the height of the instrument (HI) as described in “Determining the Height of Instrument.” *Example:* 30.55 m (100.23 ft) *Benchmark elevation*
 $+ 1.32\text{ m}$ (4.34 ft) *On-grade rod reading*

 31.87 m (104.57 ft) *Height of instrument*
3. Add 1-m (4-ft) to the finished-floor elevation (look on the blue print for this information). *Example:* *Finished-floor elevation = 31 m (101.00 ft)*

$$\begin{array}{r} 31.0\text{ m} \text{ (} 101.00\text{ ft)} \\ + 1.0\text{ m} \text{ (} 4.00\text{ ft)} \\ \hline 32.0\text{ m} \text{ (} 105.00\text{ ft)} \end{array}$$

4. Calculate the difference between the HI and the 1-m (4-ft) reference elevation mark.

Example: 32.00 m (105.00 ft) *4-ft reference elevation*
 $- 31.87\text{ m}$ (104.57 ft) *Height of instrument*

 $.13\text{ m}$ ($.43\text{ ft}$) *Difference*

5. From the end of a wooden stick, measure the difference between the two readings and make a mark. (*Using the example above, you would make a mark .13 m (43 ft) from the end of the stick.*)

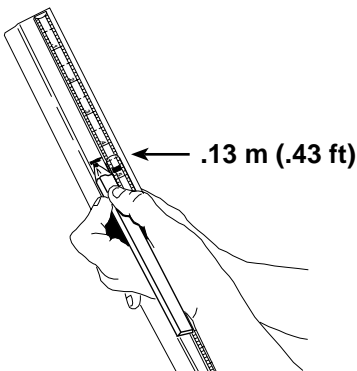

Establishing 1-Meter (4-Foot) Reference Marks (cont.)

6. Remove the general-purpose clamp (with the receiver attached) from the grade rod and attach it to the wooden stick.
7. Position the general-purpose clamp so that its alignment marks align with the mark on the wooden stick.
8. Place the wooden stick anywhere you need a 1-m (4-ft) reference mark, and raise/lower the wooden stick until the receiver shows an on-grade reading. See "Using the Receiver" for more information.
9. Mark the end of the wooden stick

Important Note: If the 1-m (4-ft) reference elevation is above the HI, mark the top of the stick.

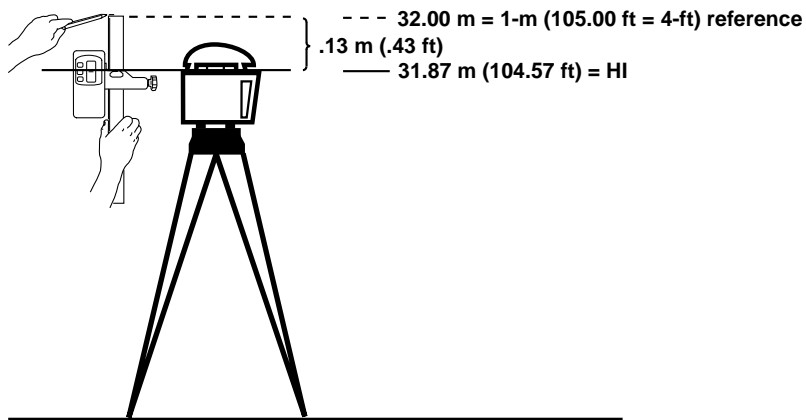

Important Note: If the 1-m (4-ft) reference elevation is below the HI, mark the bottom of the stick.

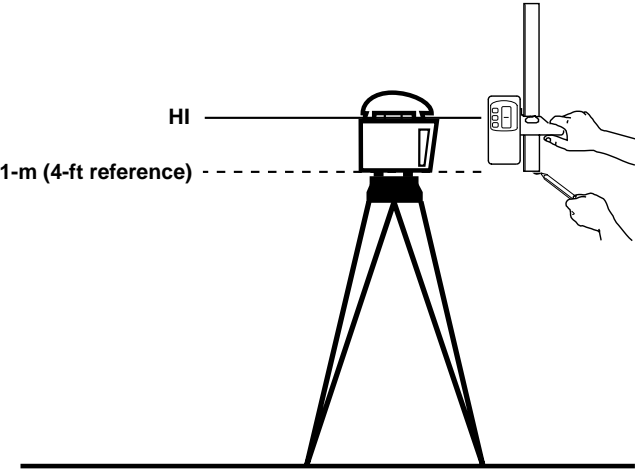

Determining the Difference in Elevation

1. Set up and level the laser as described in “Setting Up the Laser in Automatic Self-Leveling Mode.”
2. Determine the height of the instrument (HI) as described in “Determining the Height of Instrument.”
3. Place the grade rod on the point where you need an elevation reading.
4. Slide the receiver up/down the grade rod until the LCD shows an on-grade reading (rod reading A). For more information about using your receiver, see the receiver’s operator’s manual.
5. Calculate the difference between the HI and rod reading A. See the illustration below for more information.
6. Place the grade rod on another point where you need an elevation reading.
7. Slide the receiver up/down the grade rod until the LCD shows an on-grade reading (rod reading B).

8. Calculate the difference between the HI and rod reading B. See the illustration below for more information.

Note: If you are working well above or below the laser beam, use the 1278 remote display (optional accessory). The cable lets you mount the remote display at eye level on a rod.

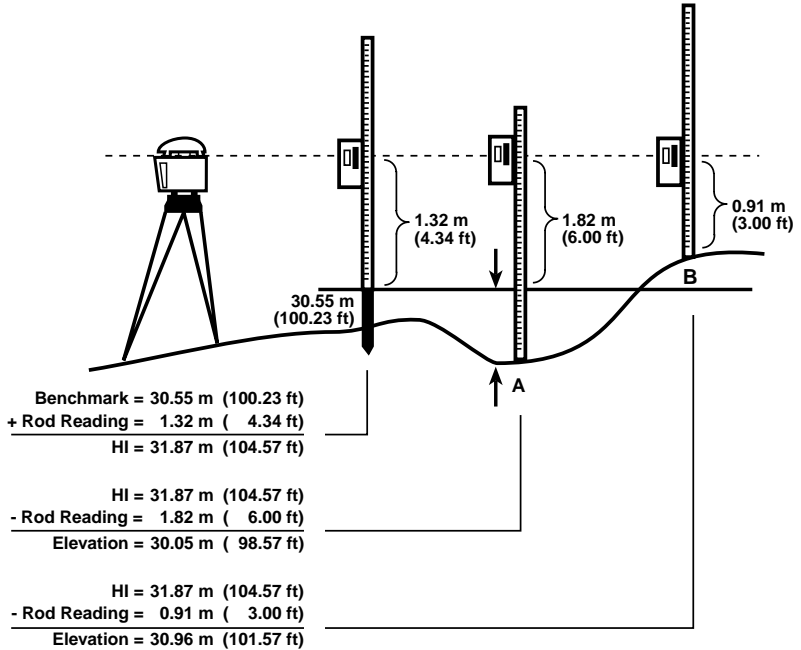

Using the Pointing-Control Knob for Grade-Axis-Alignment Applications

General Application

1. Set up a tripod to the height appropriate for your applications needs. Make sure one of the tripod legs is aligned in the direction of the desired grade.
2. Attach the laser to the tripod. Make sure the laser's handle is directly over the tripod leg that is aligned with the desired grade direction.
3. Align the axes guides on the laser's pointing-control knob with the axes marks on the laser's sunshade.
4. Using the axes guides as a reference, rotate the laser enough to fine align it with the desired main axis. A direction pole may be needed to make the final alignment.

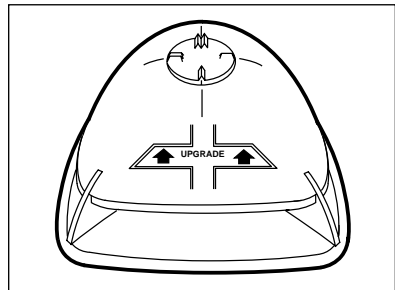
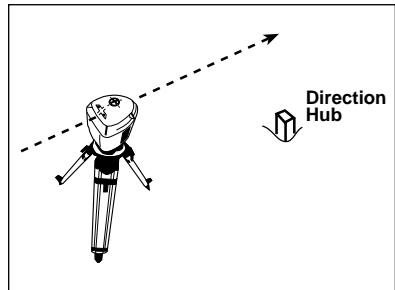

Short-Run Pipe-Laying Application

1. Set up a tripod to the height appropriate for your applications needs. Make sure one of the tripod legs is aligned in the direction of the desired grade.
2. Attach the laser to the tripod and turn the laser on.
3. Stop the beam's rotation.
4. Align the axes guides on the pointing-control knob with the axes marks on the laser's sunshade.

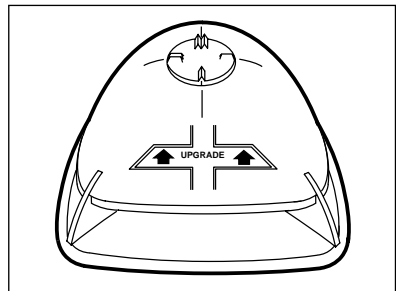
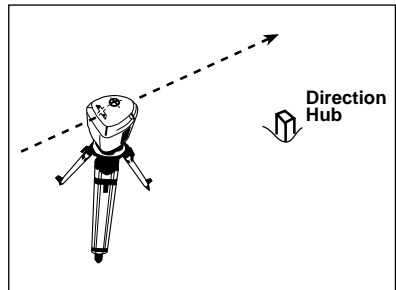

5. Using the axes guides on the pointing-control knob as a reference, rotate the laser so that it aligns with a reference point on a wall—window edge, door frame, etc.—at least 15 m (50 feet) away. Make sure the laser's handle is oriented in the same direction.
6. Using the pointing-control knob, point the laser beam so that it can be seen on the reference point on the wall (window edge, door frame, etc.).

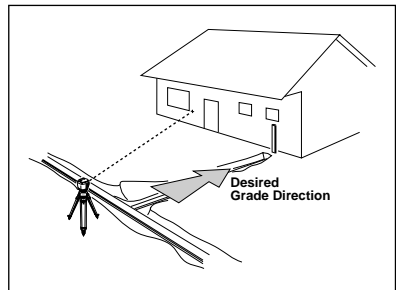

7. Align the axes guides on the pointing-control knob with the axes marks on the laser's sunshade.
8. Using the axes guides on the pointing-control knob as a reference, rotate the laser enough to fine align it with the desired grade direction.

Specifications

Laser Type/Classification	635 nm visible, Class IIIa
Compensation Method	Wire-hung, air-dampened AccuGuard™ compensator
Manual Leveling Method	Two-screw leveling base with electronic leveling LEDs
Self-Leveling Range	Up to 10% grade
Horizontal Leveling Accuracy	±8 arc seconds <±1.5 mm per 30 m (<±1/16 in. per 100 ft) ±1.7 mm per km double run leveling
Beam Diameter	12.5 mm. (1/2 in)
Operating Diameter	Target – 120 m (400 ft) Receiver – 800 m (2600 ft)
Rotation Speeds	0, 50, 300, and 600 rpm
Grade Range	0.10% to 25.0%
Grade Increments	0.01% steps from 0.10% to 2.50% 0.02% steps from 2.52% to 5.00% 0.05% steps from 5.05% to 10.0% 0.1% steps from 10.1% to 25.0%
Grade Accuracy	0.10-0.99% = ±0.06% total 1.00-2.98% = ±0.15% total 3.00-25.0% = ±6.0% of the included grade
Accuracy Over Temperature Change	±20 arc seconds
Power Source	4 D-cell alkaline or Ni-Cd (4.4 Amp hr) battery
Battery Life 20° C (68° F)	Alkaline: >80 hours Ni-Cd: >24 hours
Automatic Shutoff	Shuts off the laser if it is not leveled in automatic mode after 10 minutes
Tripod Screw	5/8-11
Operating Temperature	-20° to +50° C (-4° to 122° F)
Storage	-23° to +60° C (-10° to 140° F)
Dimensions (T x W x L)	19.0 x 16.0 x 24.1 cm (7 1/2 x 6 1/4 x 9 1/2 in.)
Weight	2.9 g (6 lb 3 oz)

Maintenance and Care

You will get years of service from the leveling system by following the maintenance and care recommendations in this manual. Carry the laser in its moisture-resistant, field-tested carrying case to safely move the laser from one job to another.

However well the product is designed, mishaps do occur. The most common problems associated with these are covered in the following areas.

Storage

CAUTION: Do not store the laser in a wet carrying case. If the case gets wet, open it and let it dry before storing the laser.

Battery Disposal

Some states and local areas have regulations regarding the disposal of rechargeable batteries. Be sure that replaced batteries are disposed of properly.

System Cleaning

Use only a good-quality glass cleaner and a soft cloth to clean all external optical components. A dry cloth used on the laser exit windows, LaserEye receiving window, or displays could scratch or damage these surfaces.

Monthly, wipe off with a moist, clean cloth any dust or dirt from the laser's outer surface, inside the battery housing, and within the leveling base. Blow off any loose debris before cleaning any surfaces to prevent scratching of optical surfaces.

Troubleshooting

If none of the following techniques corrects the problem, take your system to a local Trimble dealer or authorized service center for evaluation or repair.

Problem	Solution
Laser will not operate	<ul style="list-style-type: none">• Press power button.• Check or replace batteries.• Return laser to service center for inspection.
Laser out-of-level indicator does not shut off	<ul style="list-style-type: none">• Make sure the laser is mounted to a stable surface.• Press mode button so that the laser is in automatic self-leveling or grade mode.• Make sure the leveling screws are free to turn.• Allow the laser to re-level.• Return laser to service center for inspection.
SafeGuard LED is on	<ul style="list-style-type: none">• Check and adjust laser plane calibration as necessary.• Return laser to service center for inspection.
Laser plane not accurate	<ul style="list-style-type: none">• Check and adjust laser plane calibration as needed.• Return laser to service center for inspection.

Calibration

As with any precision instrument, the calibration needs checking on a regular basis (such as the beginning of each job, or if the laser has been handled roughly). If the laser is to be used below freezing, be sure to check calibration under those conditions.

The laser has a calibration error when the laser plane coming out one side of the laser is above true level, and the laser plane coming out the opposite side is below true level. Adjusting the position of the laser plane requires making minor adjustments to the axis-calibration screws found immediately above the laser's leveling screws.

When the laser is properly calibrated, it emits a 360° horizontal level plane so that if the laser is turned 180° or 90° from its original position, the reading is within ± 3.0 mm/30 m ($\pm 1/8$ in. per 100 ft) of the original position.

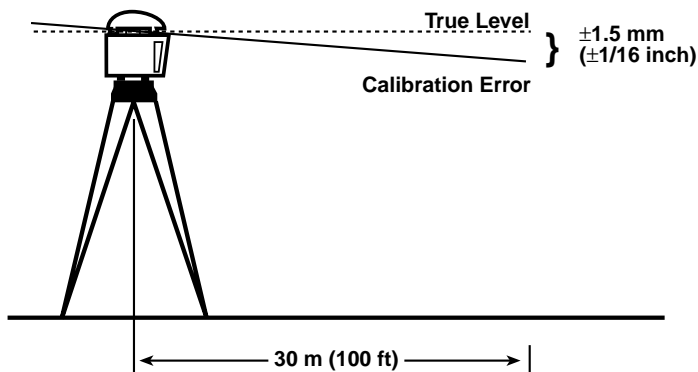

To check the horizontal calibration, you'll need a tripod with a $5/8$ -11 threaded mount, receiver, and 1.5 mm ($1/16$ in.) diameter pin or small nail. If you need to adjust the calibration, having another person to help saves time.

Calibration (cont.)

1. Set up and level the laser 30 m (100 ft) from a wall.

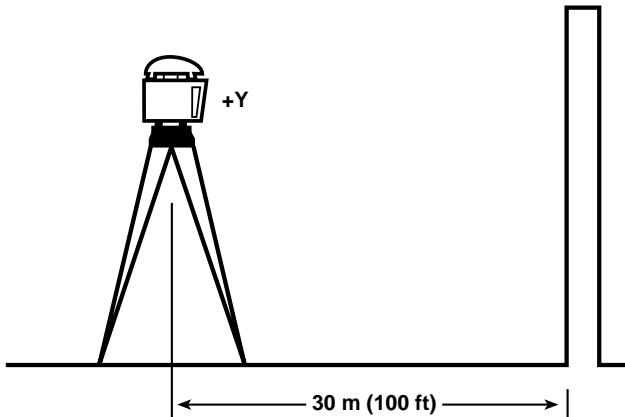

2. Raise/lower the receiver until you get an on-grade reading for the +Y axis. Using the on-grade marking notch as a reference, make a mark on the wall.

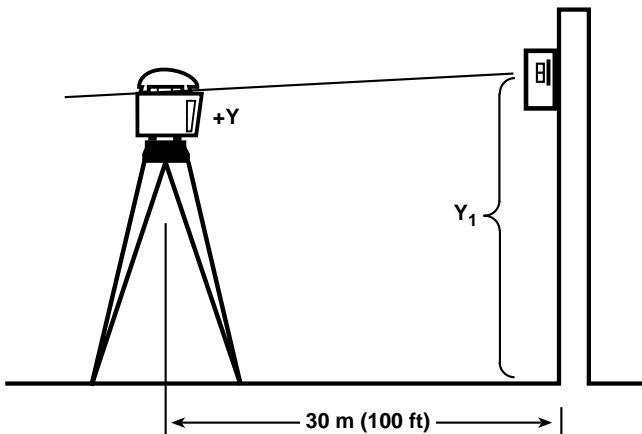

Note: For increased precision, use the fine-sensitivity setting (± 1.5 mm/ $\pm 1/16$ in.) on the receiver.

3. Rotate the laser 180° (-Y axis toward the wall) and re-level the laser.

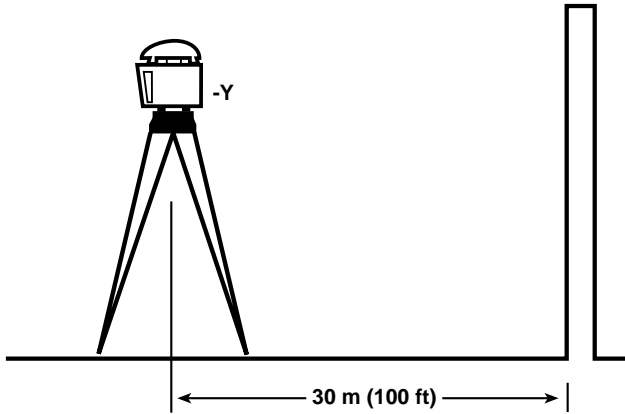

4. Raise/lower the receiver until you get an on-grade reading for the -Y axis. Using the on-grade marking notch as a reference, make a mark on the wall.

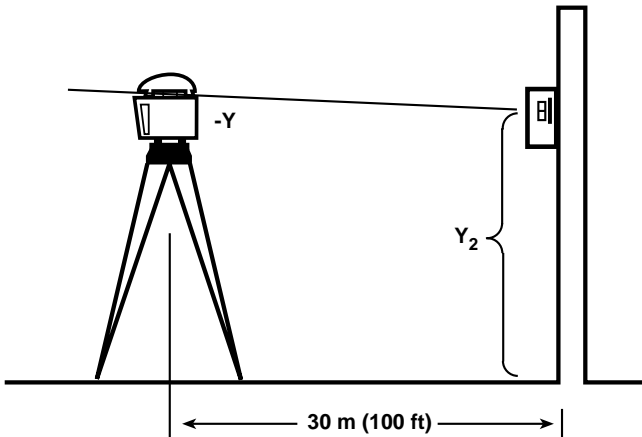

5. Measure the difference between the two marks. If they differ more than 3 mm (1/8 in.), the laser needs calibrating.

Calibration (cont.)

6. To correct for a calibration error, position the receiver at the midpoint of the two marks on the wall.

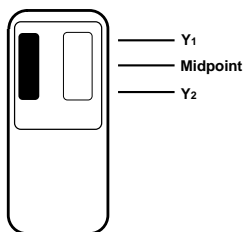

Note: Although you can calibrate the laser by yourself, having another person to help saves time.

7. To adjust the calibration, insert a nail (1.5 mm or $1/16$ in. diameter) into the opening in the calibration screw and turn the screw in the appropriate direction.



Note: The arrows on the display show which direction the calibration screws need turning. An up arrow on the receiver indicates that the Y axis calibration screw needs to be turned clockwise to lower the laser plane. A down arrow on the receiver indicates that the Y axis calibration screw needs to be turned counterclockwise to raise the laser plane.

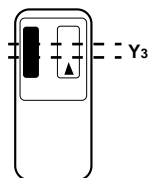

**Up arrow-
turn calibration
screw clockwise**

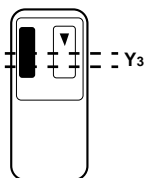

**Down arrow-
turn calibration screw
counterclockwise**

8. Rotate the laser 180° back to the original face. Make sure this axis is less than 3 mm (1/8 in.) from the midpoint line.

Note: If additional adjustment is required, repeat steps 2–7 above.

9. After adjusting the Y axis, rotate the laser 90°. Repeat steps 2–8 above starting with the +X axis facing the wall.

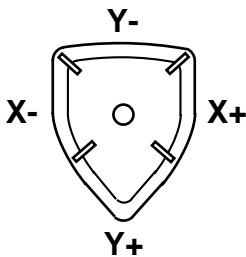

Service

Our goal is to provide prompt and efficient service through competent service dealers. To locate your local dealer or authorized Trimble Service Center, contact one of our offices our listed below.

North America

Trimble Engineering and
Construction Division
5475 Kellenburger Road
Dayton, Ohio 45424-1099
U.S.A.
(800) 538-7800
(Toll Free in U.S.A.)
+1-937-233-8921 Phone
+1-937-233-9004 Fax
www.trimble.com

Africa & Middle East

Trimble Navigation Limited
P.O. Box 17760
Jebel Ali Free Zone, Dubai
UAE
+971-4-881-3005 Phone
+971-4-881-3307 Fax

Europe

Trimble GmbH
Am Prime Parc 11
65479 Raunheim
GERMANY
+49-61422-1000 Phone
+49-6142-2100-550 Fax

Asia-Pacific

Trimble Navigation
Australia Pty Limited
Level 1/123 Gotha Street
Fortitude Valley, QLD 4006
AUSTRALIA
+61-7-3216-0044 Phone
+61-7-3216-0088 Fax

Latin America

Trimble Navigation Limited
6505 Blue Lagoon Drive
Suite 120
Miami, FL 33126
U.S.A.
+1-305-263-9033 Phone
+1-305-263-8975 Fax

China

Trimble Export Limited
Representative Office
Suite 16D, Building 2
Epoch Center
4 Beiwa Road, Haidian District
Beijing 100089
P.R. CHINA
+86-10-6847-7756 Phone
+86-10-6847-7786 Fax

Before returning your system for repair, be sure to do the following:

1. Put a note into the package identifying yourself as the owner.
2. Explain the operating difficulty.
3. Include a return address and phone number.
4. If the laser is in warranty, provide verification of the date of purchase.
5. Pack the equipment securely for shipment in its original carrying case.
6. Return the equipment prepaid and insured to your local dealer or authorized Trimble Service Center.
7. Request estimate of charges for non-warranty or other service work before repair begins. If estimates are not requested, repair work will begin immediately.

All certified outlets have factory-trained personnel and use authorized replacement parts to ensure proper and quick return. For long-distance shipments, UPS, 2nd-Day Air, or air freight is recommended.

Except for one-way transportation charges, there will be no charge for repairs caused by problems due to defective materials and/or workmanship under warranty.

Laser Safety

This laser complies with all applicable portions of Title 21 of the code of Federal Regulations, Department of Health and Human Services, Food and Drug Administration (Federal Register, Volume 50, Number 161, August 20, 1985).

As with any visible laser device, the following safety rules should be observed:



- Never look directly into a laser beam or point the beam into the eyes of others. Set the laser at a height that prevents the beam from shining directly into people's eyes.
- Do not remove any warning signs from the laser.
- Use of this product by people other than those trained on this product may result in exposure to hazardous laser light.
- If initial service is required, which results in the removal of the outer protective cover, removal must only be performed by factory-trained personnel.

Questions about laser safety should be addressed to:

Trimble Engineering and Construction Division
5475 Kellenburger Road
Dayton, OH U.S.A. 45424-1099

Attention: Quality Assurance Group, Laser Safety Officer

Labels required for this product:



5475 Keilenburger Rd.
Dayton, Ohio 45424-1099 U.S.A.

COMPLIES WITH 21 CFR 1040 AS APPLICABLE

N324 MFG: [REDACTED]

S/N [REDACTED] MODEL: [REDACTED]



LASER LIGHT
IS EMITTED FROM
THIS APERTURE

AVOID EXPOSURE



**LASER LIGHT
AVOID DIRECT
EYE EXPOSURE**

CLASS 3R LASER PRODUCT PER
IEC / EN 60825-1:2001 AND
CLASS 3A LASER PRODUCT PER
CDRH 21 CFR 1040.10 AND 1040.11
POWER < 5 mW AVERAGE
WAVELENGTH 635nm

DANGER

LASER LIGHT
WHEN OPEN.
AVOID DIRECT
EYE EXPOSURE

EMC Declaration of Conformity

This laser has been tested and found to comply with the limits for a Class B digital device for radio noise for digital apparatus set out in the Radio Interference Regulations of the Canadian Department of Communication, and is pursuant to part 15 of the Federal Communication Commission (FCC) rules. These limits are designed to provide reasonable protection against harmful interference in a residential installation. This laser generates radio frequency. If it's not used in accordance with the instructions, it may cause harmful interference to radio or television reception. Such interference can be determined by turning the laser off and on. You are encouraged to try eliminating the interference by one or more of the following measures:

- Reorient or relocate the receiving antenna.
- Increase the separation between the laser and the receiver.

For more information, consult your dealer or an experienced radio/television technician.

CAUTION: Changes or modifications to the laser that are not expressly approved by Spectra Precision could void authority to use the equipment.

Application of Council Directive(s):	89/336/EEC
Manufacturer's Name:	Trimble
Manufacturer's Address:	5475 Kellenburger Road Dayton, Ohio 45424-1099 U.S.A.
European Representative Address:	Trimble Engineering and Construction GmbH Am Prime Parc 11 Siemensstrasse 20 D-64289 Darmstadt, Germany
Model Number(s):	1242
Conformance to Directive(s):	EC Directive 89/336/EEC using EN55022 and EN50082-1
Equipment Type/Environment:	ITE/residential, commercial & light industrial
Product Standards:	Product meets the limit B and methods of EN55022 Product meets the levels and methods of IEC 801-2, 8 kV air, 4 kV contact, IEC 801-3, 3 V/m 26 to 1000 MHz 80%, @ 1 kHz IEC 801-4, ac leads 2 kV

Warranty

Trimble warrants the 1242 laser and receiver to be free of defects in material and workmanship for a period of two years. This warranty period is in effect from the date the system is delivered by Trimble or its authorized Dealer to the purchaser, or is put into service by a Dealer as a demonstrator or rental components.

Additionally, items covered by the standard Trimble one-year warranty are the accessories. All other components not manufactured by Trimble but sold as a part of the system such as tripods and grade rods, will carry a 90-day warranty or the manufacturer's warranty, whichever is greater.

Trimble or its Authorized Service Center will repair or replace, at its option, any defective part of components of which notice has been given during the warranty period. A Warranty Registration Card must be filled out properly and on file with Trimble Service Department before warranty repair or replacement can be approved. Travel and per diem expenses, if required, to and from the place where repairs are made will be charged to the purchaser at the prevailing rates.

Customers should send products to the nearest Authorized Factory Service Center for warranty repairs, freight prepaid. In countries with Trimble Subsidiary Service Centers, the repaired products will be returned to the customer, freight prepaid.

Any evidence of negligent, abnormal use, accident, or any attempt to repair equipment by other than factory-authorized personnel using Trimble certified or recommended parts, automatically voids the warranty.

Special precautions have been taken to ensure the calibration of the laser; however, calibration is not covered by this warranty. Maintenance of the calibration is the responsibility of the user.

The foregoing states the entire liability of Trimble regarding the purchase and use of its equipment. Trimble will not be held responsible for any consequential loss or damage of any kind.

This warranty is in lieu of all other warranties, except as set forth above, including an implied warranty merchantability of fitness for a particular purpose, are hereby disclaimed. This warranty is in lieu of all other warranties, expressed or implied.

Notes

Notes

Notes



Trimble Engineering and Construction Division
5475 Kellenurger Road
Dayton, Ohio 45424-1099
U.S.A.
+1-937-233-8921 Phone

www.trimble.com



© 2002, Trimble Navigation Limited. All rights reserved.
Reorder PN 1242-0100 Rev B. (06/02)